

**1. Press the hinge button down and fold the stem up.**

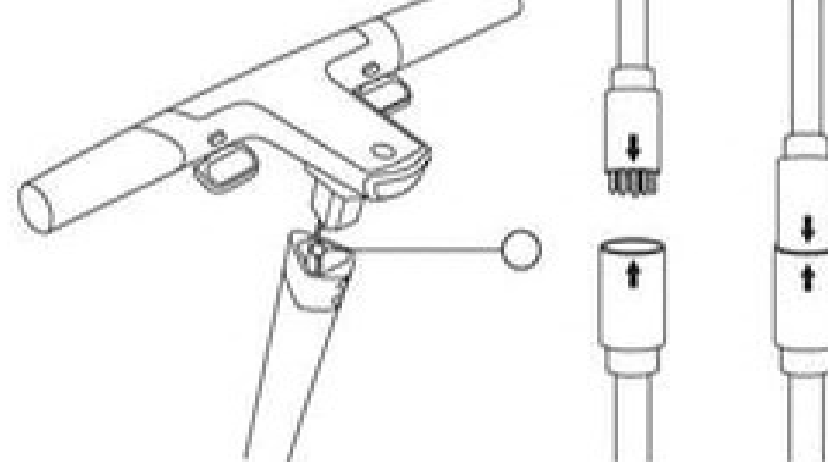

**2. Connect handlebar and tube cable.**

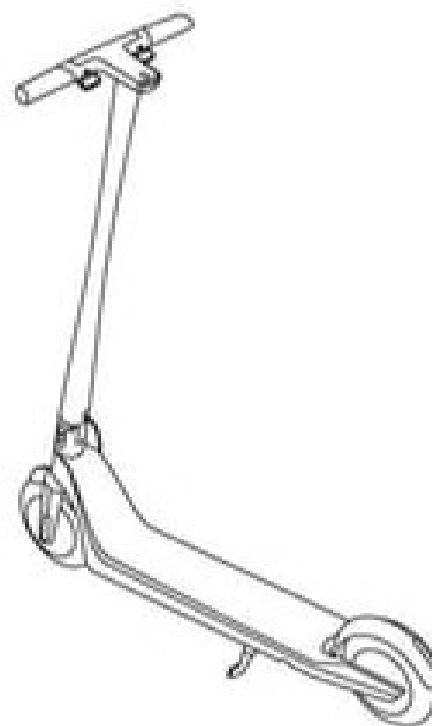

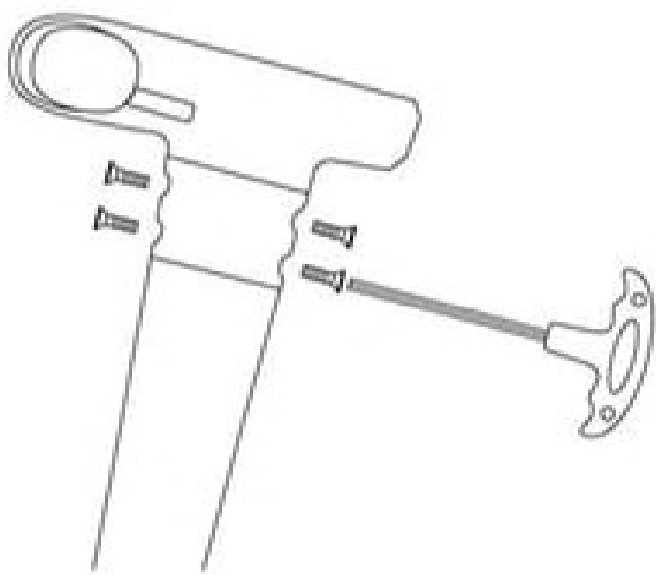
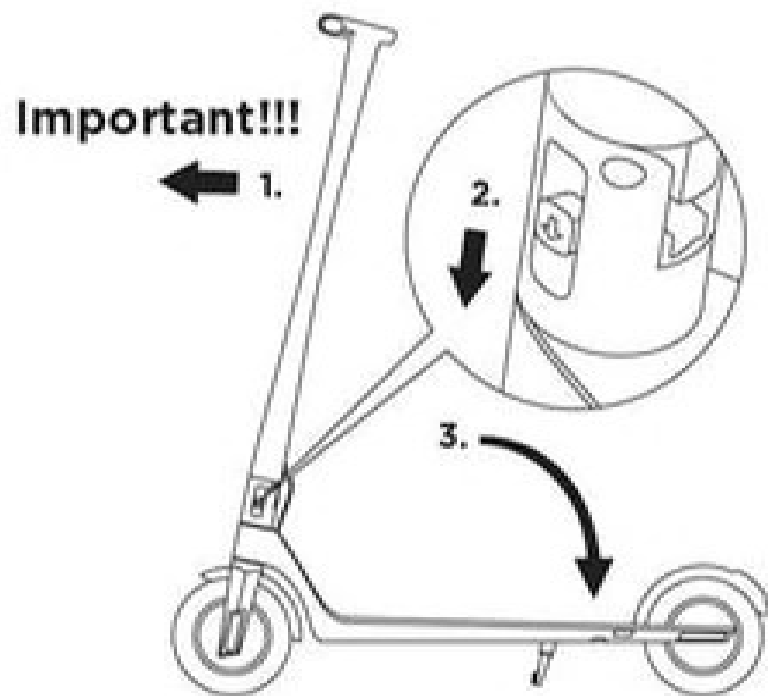

- 1. Important:** Push tube forward slightly.
2. Press hinge button down.
3. Fold handlebar down.

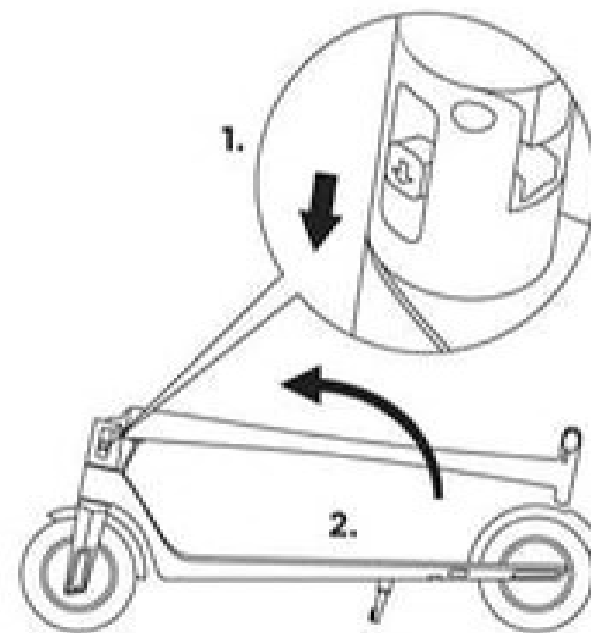

1. Press hinge button down.
2. Fold handlebar up.

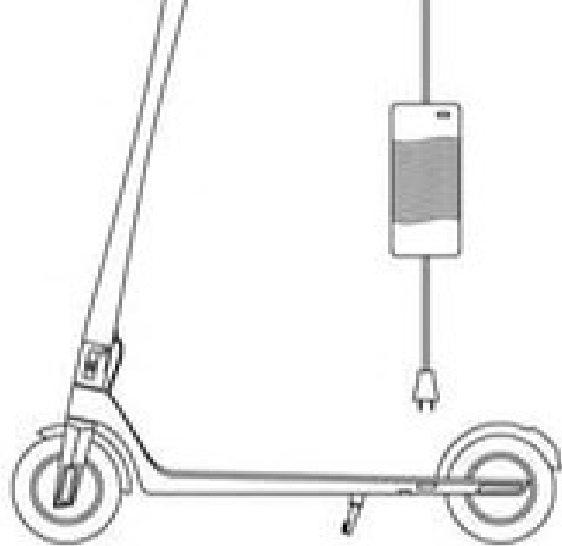

**1. Plug in the charger.**

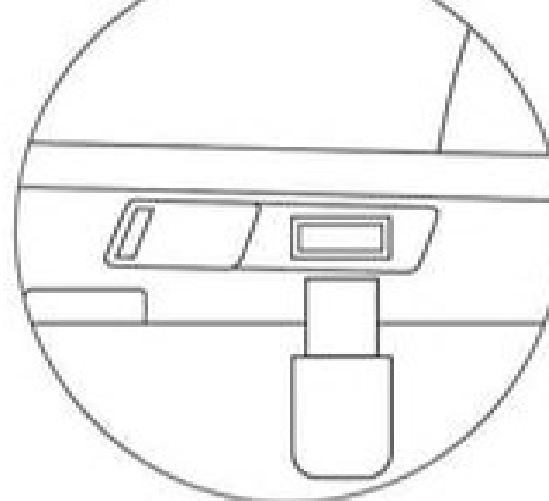

**2. Open deck cover plug in.**

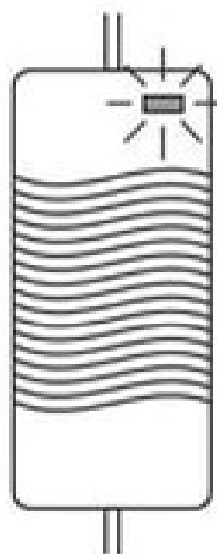

Press and hold to activate the horn

Release to turn off the horn

Click to switch between trip mileage  
and total mileage

Double click to change mode  
(beginner, intermediate, advanced)

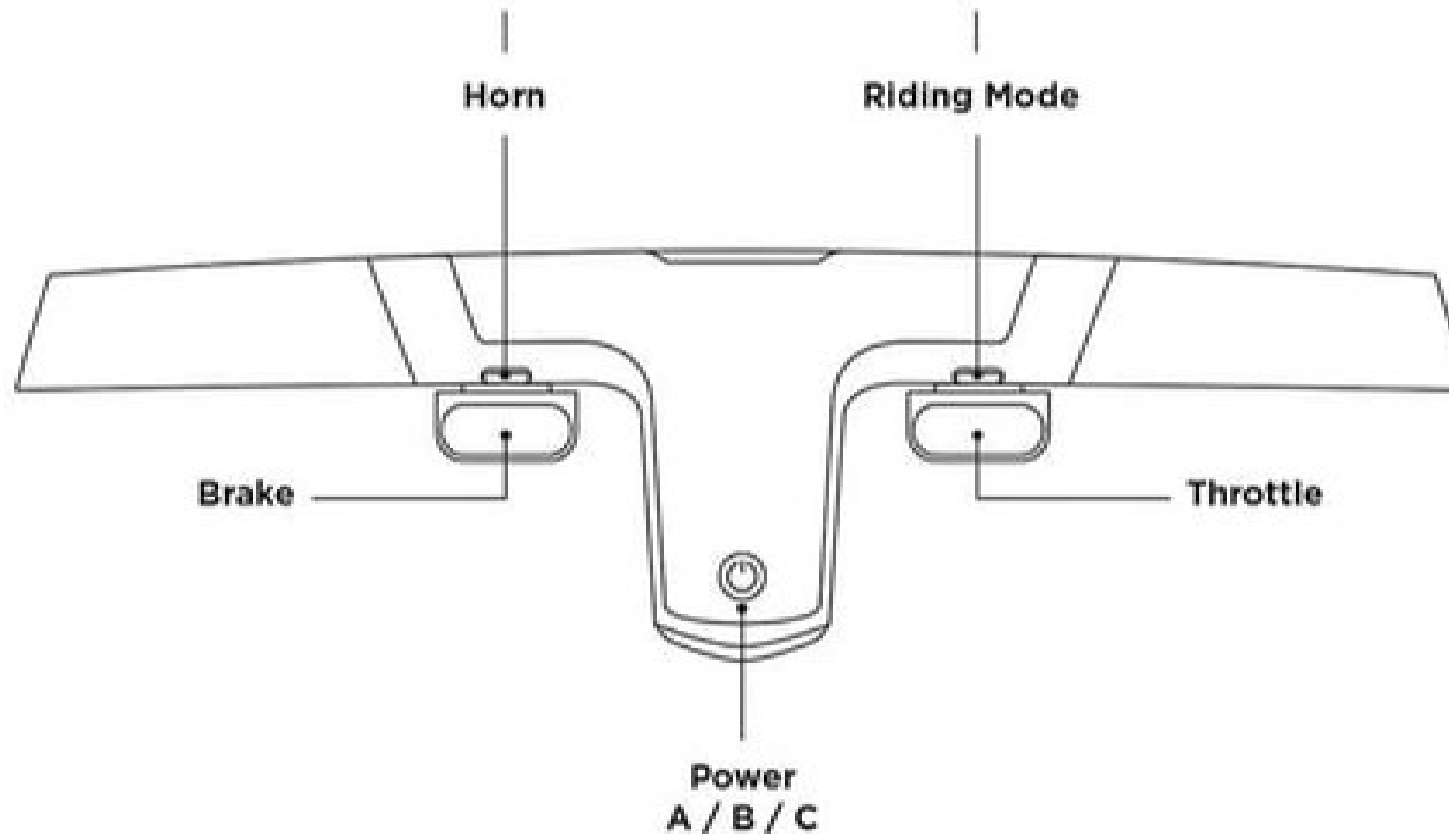

**A Power (On/Off):** Press and hold for 3 seconds. Motor will automatically turn off after 3 minutes if not in use.

**B Light (On/Off):** Click to activate or deactivate the light.

**C Single/Dual Motor Mode:** Press 2 times to alternate between single/dual motor mode. The dual motor icon will be displayed on screen when activated.

**Odometer Mode:** Press the Horn button and the Riding mode button for 2 seconds simultaneously to switch

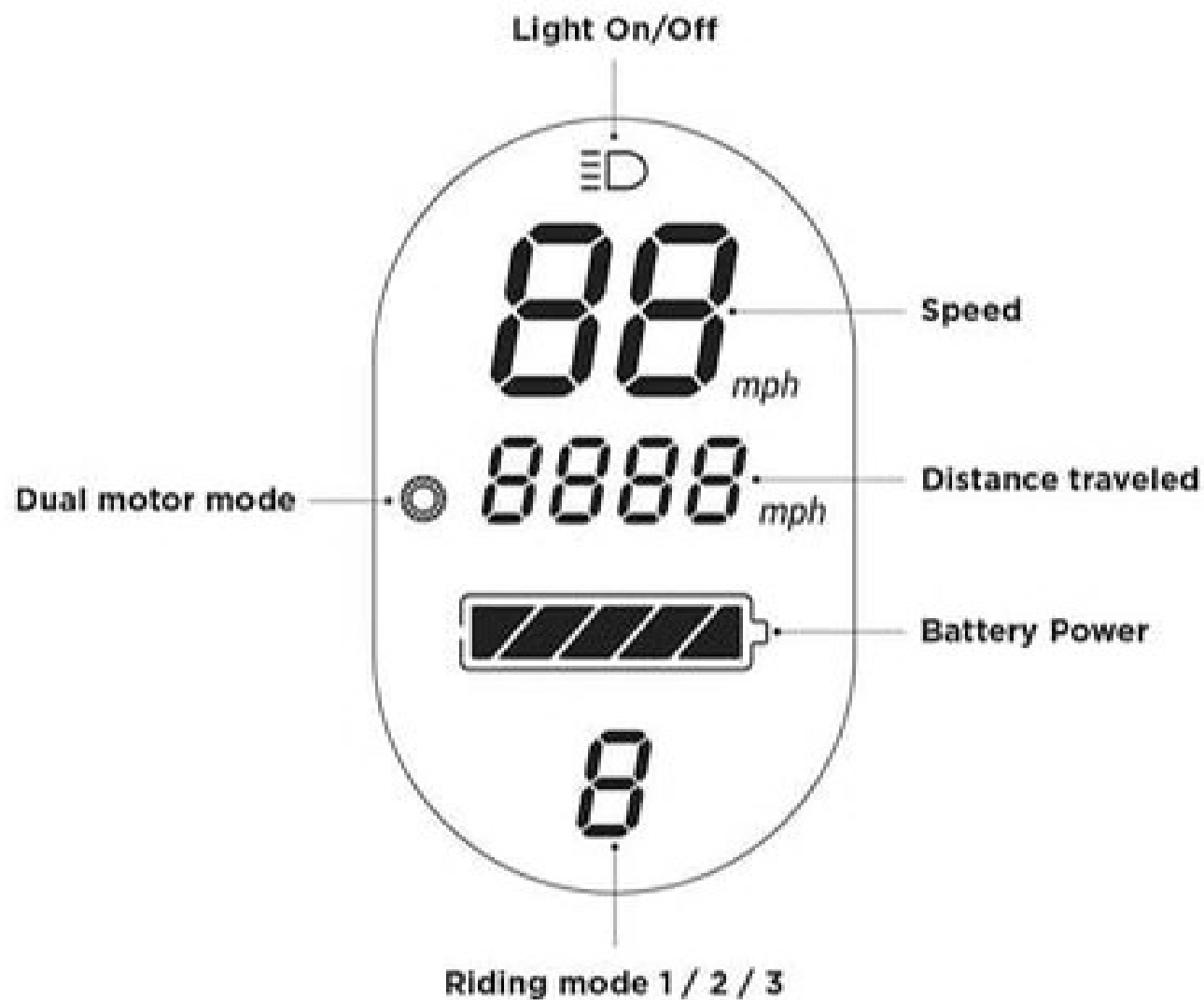

1

**Beginner (Eco-mode)**  
 Riding experience: soft and smooth  
 Maximum speed: 9.3mph

2

**Intermediate (Standard mode)**  
 Riding experience: balanced  
 Maximum speed: 12.4mph

3

**Advanced mode (Sport mode)**  
 Riding experience: a lot of power  
 Maximum speed: 15.5mph



**1.** Please wear a helmet when riding. Check the dashboard after turning it on. Make sure you are using the beginner mode when you first start to ride.



**2.** Start your ride on a flat surface, put one leg on the deck the other one on the ground. Kick the ground to start.

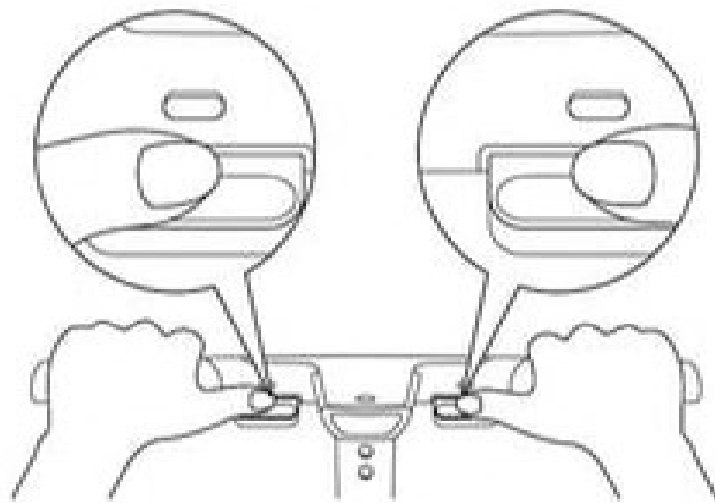

**3.** Put both feet on the deck after the scooter starts.



**4.** Slow down when turning, turn your body and